

## Description

This is a range of float type automatic liquid drainers for air and gas systems. It is designed for using the place where much amount of drain is expected such as separator on air main, after cooler, inter cooler, air cooler, air receiver dryers, oil coolers and many more. This trap has simple construction and reliable operation due to their lever float type, with Cast Steel bodies. It is available in horizontal flanged connections.

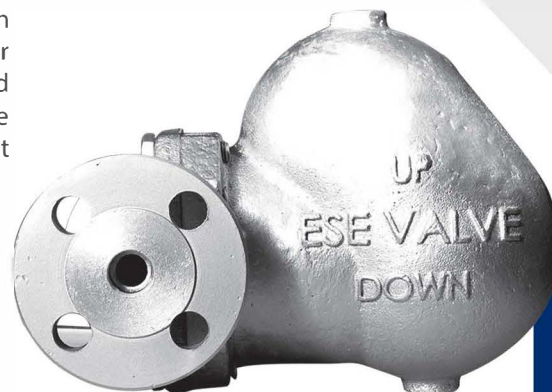

## Limiting Conditions

Body Design Conditions	PN25
PMO - Maximum Operating Pressure	14 kgf/cm <sup>2</sup>
TMO - Maximum Operating Temperature	300 °C
PMA - Maximum Allowable Pressure	25 kgf/cm <sup>2</sup>
TMA - Maximum Allowable Temperature	350 °C
Cold Hydraulic Test Pressure	38 kgf/cm <sup>2</sup>

## Operating Range

$\Delta$ PMX – Maximum differential pressure

Model	$\Delta$ PMX
992AT - 5	5 kgf/cm <sup>2</sup>
992AT - 14	14 kgf/cm <sup>2</sup>

## Sizes and Pipe Connections

DN 15, 20, 25 Flanged (ANSI B16.5)

## Dimensions / Weights (Approximate) mm and kg

Size	A	B	C	F-F	Weight
DN15	140	80	240	210	17
DN20	140	80	240	210	17.5
DN25	140	80	240	210	18

Construction are a bit different according the sizes

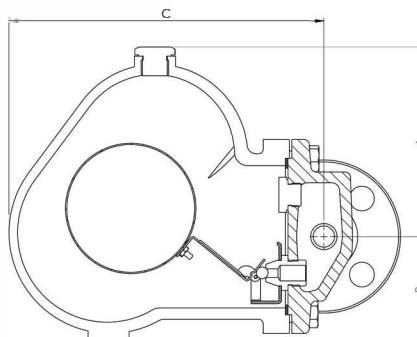

Design and specification are subject to change without notice



**E.S.E. Valve Co. Ltd.**  
**02156897607**  
**09102551161**

E.S.E. Valve Co.

## Ball Float Air & Gas Traps - 992

### Materials

No.	Part	Material
1	Body	ASTM A216 WCB
2	Seat *	AISI 316
3	Support *	AISI 316
4	Bolt	Stainless Steel
5	Lever *	AISI 316
6	Pivot Pin	Stainless Steel
7	Ball Float *	AISI 316
8	Nut	Stainless Steel
9	Plug	Stainless Steel
10	Cover Gasket *	Reinforced Exfoliated Graphite
11	Cover	ASTM A216 WCB
12	Bolt M12x1.5x40	ASTM F568M 10.9
13	Air Balance Plug	ASTM A105

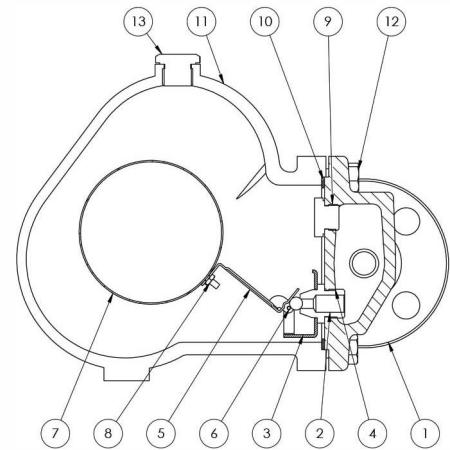

Note: (\*) Spare Part

### Capacities

Maximum continual discharge amount (Kg/h)

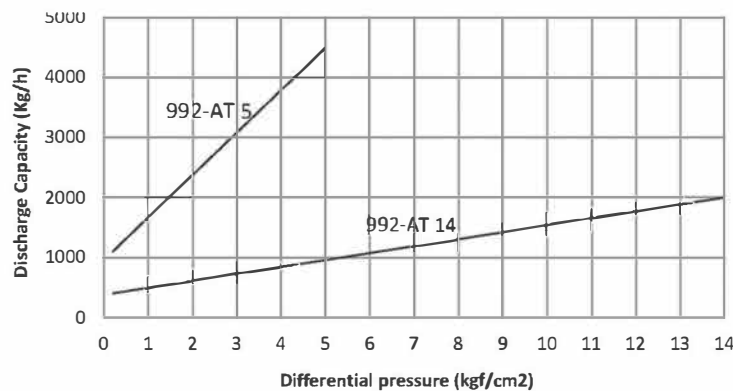

Note: Water entering the trap lifts the float and opens the discharge valve. This adjusts the valve opening so that there is a continuous flow of water through the trap. There are no pressure fluctuations as the trap opens and closes.

### Installation

The trap should be installed in a horizontal pipeline with the direction of flow as indicated by the arrow on the trap body.

Note: An equalizing line should be installed. This will equalize the pressure to the trap, eliminate gas binding and permit a smooth uninterrupted flow of condensate to the trap; the equalizing line connection to the tank must be above the level of any possible accumulation of condensate.

### How to Order

Example: AT992 – DN20 – 14, Ball Float Air Trap.

Design and specification are subject to change without notice